

Esempio di applicazione / Example of application

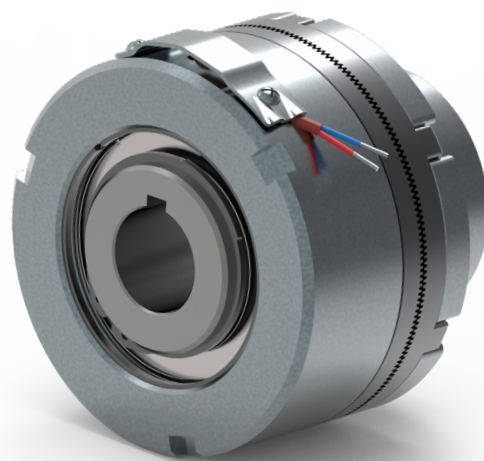

Dimensioni / Dimension

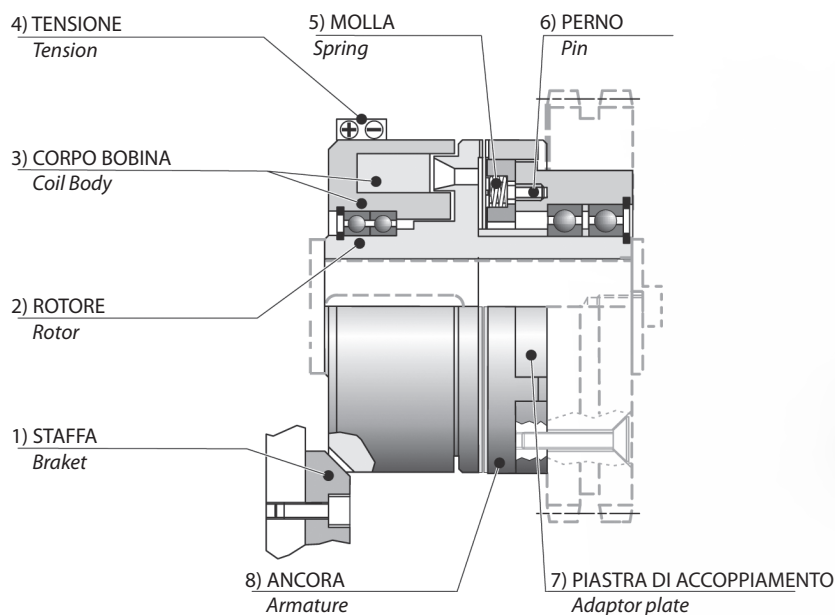
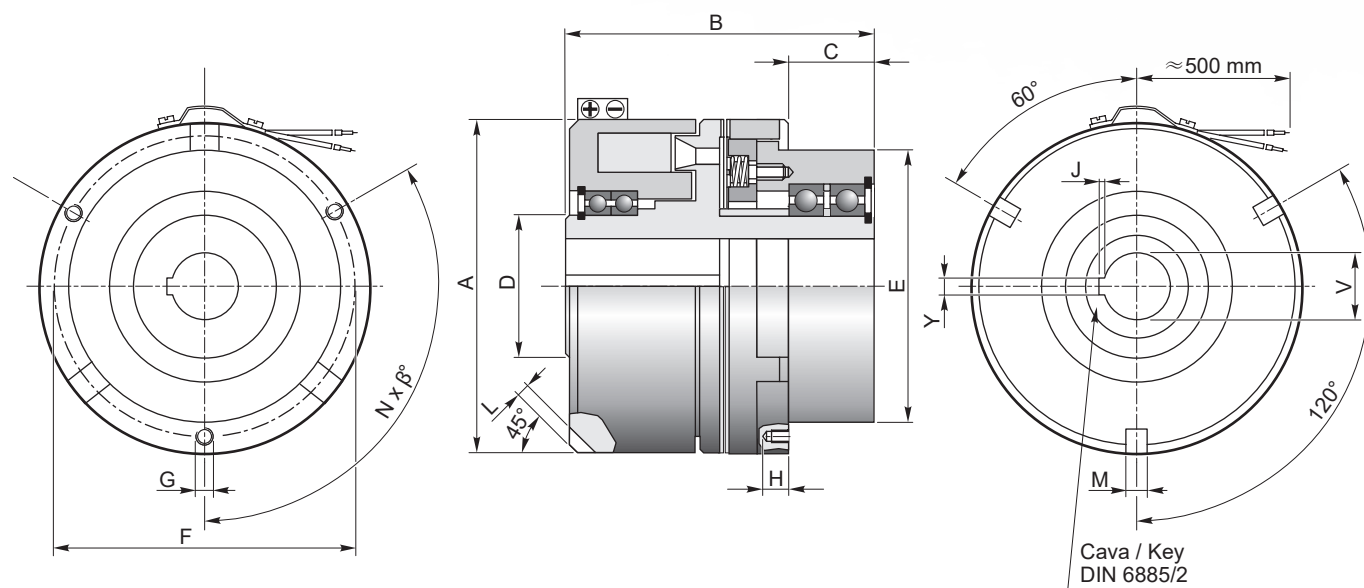

Caratteristiche / Characteristics

TAGLIA SIZE	Coppia nom. Statica Nom. Static Torque	Tensione Nominale Nominal Voltage	Potenza assorbita Input Power	n _{max}		Tempo inserzione Engagement time	Tempo disinserzione Desengagement time	Z		
	CU 1)	V (C.C - D.C)	W	a secco dry	in olio oil	ms	ms	Z		Kg
				rpm	rpm					
GD82G	100	24	40	2200	3000	20	60	130	253	2.4
GD95G	200	24	53	2000	2500	30	70	180	280	3.6
GD114G	300	24	65	2000	2500	40	100	216	280	5
GD134G	500	24	90	2000	2200	60	160	144	310	10
GD166G	1000	24	115	1800	2000	70	260	168	380	16.5
GD195G	2000	24	140	1800	2000	90	400	205	410	22.5
GD210G	3000	24	170	1500	1800	100	500	212	410	40
GD240G	4000	24	209	1500	1800	120	700	180	470	50
GD258G	6000	24	240	1500	1800	140	1000	240	470	-

1) Selezione del valore di coppia vedere pag. / Selection the torque value see page

p.4



Innesto elettromagnetico a denti con mozzo



Electromagnetic tooth clutch with hub

Codice d'ordine / Order code

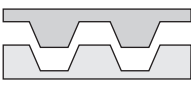
TIPO E TAGLIA TYPE AND SIZE	DENTATURA TOOTH PROFILES	CONNESSIONE CONNECTION	Ø ALBERO Ø SHAFT
	A	B	C
GD95G	1	2	1
GD82G	1	1 2	1 2
...	2		
...	3		
GD258G	4		

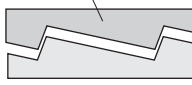
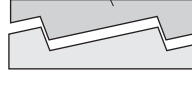
Dentatura / Tooth profiles

CODICE CODE	1	2	3	4
A	 Forma trapezoidale Trapezoidal form	 Forma triangolare Triangular form	 Dente sega SX Saw tooth anticlockwise	 Dente sega DX Saw tooth clockwise

- A richiesta dentatura in fase / On request, tooth profiles for fixed point engagement  

Connessione / Connection

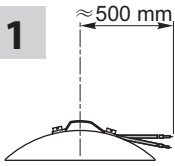
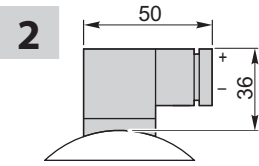
CODICE CODE	1	2
B		

Albero / Shaft

		GD..G																	
C	TAGLIA SIZE	82		95		114		134		166		195		210		240		258	
	CODICE CODE	1	2	1	2	1	2	1	2	1	2	1	2	1	2	1	2	1	2
	øV H7	18	20	20	25	25	30	35	42	40	50	40	50	50	65	50	70	60	70
	Y P9	6	6	6	8	8	8	10	12	12	14	12	14	14	18	14	20	18	20
	J	1.7	1.7	1.7	1.7	1.7	1.7	2.1	2.1	2.1	2.6	2.1	2.6	2.6	3.1	2.6	4.1	3.1	4.1
	n° Cave n° Key	1	1	1	1	1	1	1	1	1	1	2	2	2	2	2	2	2	2

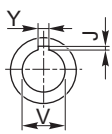

Dimensioni / Dimension

TAGLIA SIZE TAMANHO	A	B	C	D	E (h7)	F	G	N x β°	H	L	M
GD82G	82	82	18	35	65	75	M5	3 x 120°	12	3	6
GD95G	95	98	23	45	75	88	M6	3 x 120°	12	4	6
GD114G	114	97	25	50	80	96	M8	3 x 120°	12	4	8
GD134G	134	128	35	60	114	126	M6	6 x 60°	16	5	8
GD166G	166	130	25	75	136	152	M8	6 x 60°	16	6	8
GD195G	195	139	40	80	149	169	M12	6 x 60°	18	8	12
GD210G	210	195	40	85	150	174	M12	6 x 60°	20	8	12
GD240G	240	200	45	95	170	194	M12	6 x 60°	20	10	12
GD258G	258	210	50	105	180	204	M12	6 x 60°	20	10	12