

Esempio di applicazione / Example of application

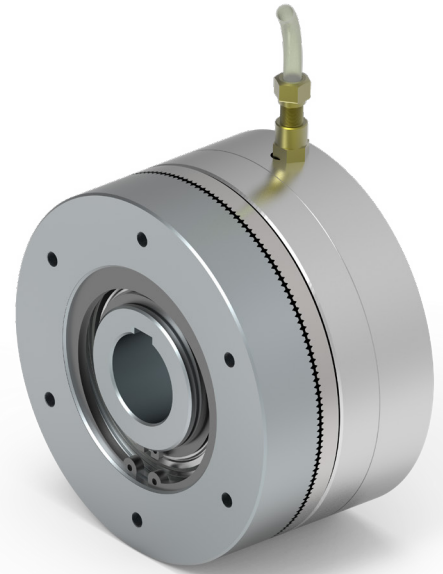

Dimensioni / Dimension

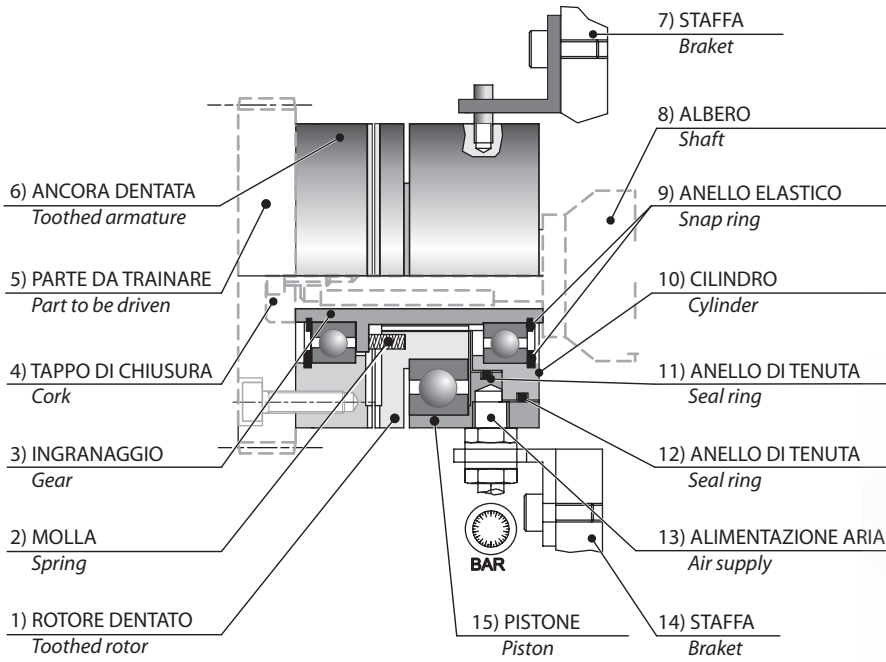
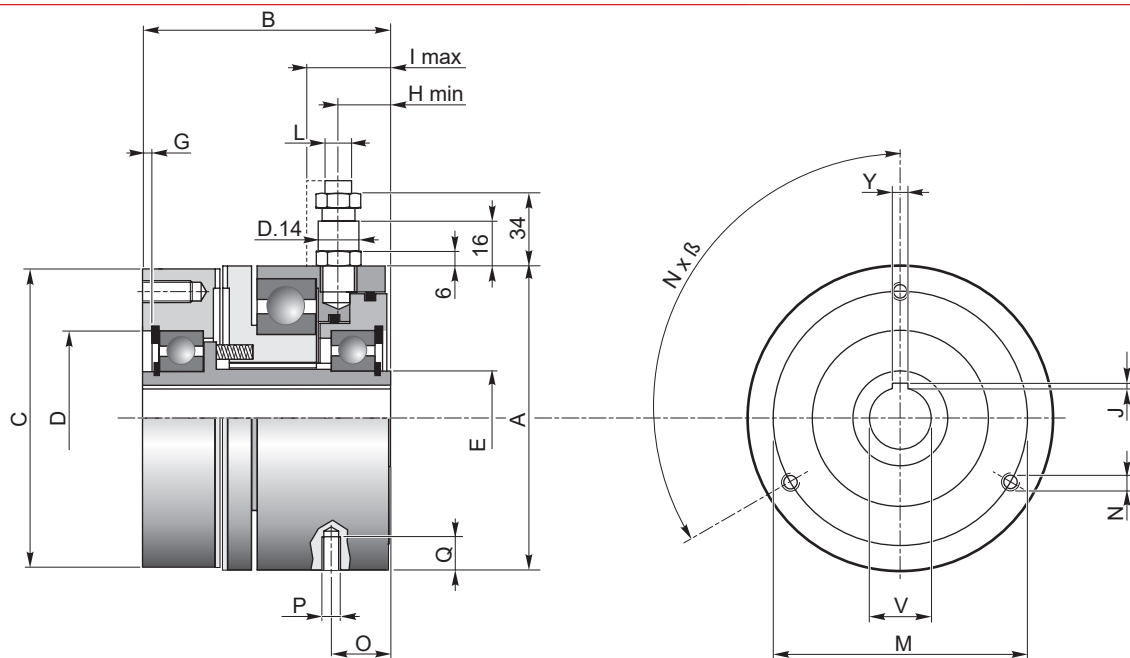

Caratteristiche / Characteristics

TAGLIA SIZE	Coppia Nom. Statica Nominal Static Torque CU 1)	Pressione Pressure	nmax	Z	Kg
	Nm	bar	rpm		
PNZ72	50	6	3500	108	1
PNZ82	100	6	3500	120	1.6
PNZ95	140	6	3000	130	2.1
PNZ114	170	6	2800	144	4
PNZ124	280	6	2500	168	4.8
PNZ134	400	6	2500	168	5.5
PNZ152	580	6	2000	180	9
PNZ166	780	6	1800	180	10
PNZ195	1350	6	1500	212	17
PNZ215	2150	6	1300	240	23
PNZ240	4000	6	1200	333	32

1) Selezione del valore di coppia vedere pag. / Selection the torque value see page

p.45

Innesto a denti pneumatico

Pneumatic toothed clutch

Codice d'ordine / Order code

TIPO E TAGLIA TYPE AND SIZE	Ø ALBERO Ø SHAFT
	C
PNZ95	2
PNZ72	1
...	2
...	3
PNZ240	4

Albero / Shaft

		PNZ..																																							
C	TAGLIA SIZE	72		82			95			114				124				134				152				166				195				215				240			
	CODICE CODE	1	2	1	2	3	1	2	3	1	2	3	1	2	3	4	1	2	3	4	1	2	3	4	1	2	3	4	1	2	3	4	1	2	3	4	1	2	3	4	
	øV	12	15	12	15	18	19	20	22	19	20	25	25	30	32	35	25	30	32	35	30	35	40	45	35	40	45	50	45	50	55	60	55	60	65	70	65	70	75	80	
	Y	4	5	4	5	6	6	6	6	6	6	8	8	8	10	10	8	8	10	10	8	10	12	14	10	12	14	14	14	14	16	18	16	18	18	20	18	20	20	22	
	J	1.8	1.3	1.8	2.3	1.7	2.8	2.8	1.7	2.8	2.8	3.3	3.3	3.3	3.3	2.1	3.3	3.3	3.3	2.1	3.3	3.3	3.3	3.8	3.3	3.3	3.8	3.8	3.8	3.8	4.4	4.4	4.4	4.4	4.4	4.4	4.4	4.4	4.9	4.1	
	n° Cave/ n° Key	1	1	1	1	1	1	1	1	1	1	1	1	1	1	1	1	1	1	1	1	1	1	1	1	1	1	1	1	1	1	1	1	1	1	1	1	1	1	1	

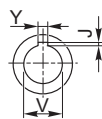

Dimensioni/ Dimension

TAGLIA SIZE	A	B	C	D (-0.01/0.03)	E	G	H Min	I Max	L	M	N x β°	N	O	P	Q
PNZ72	72	60	72	42	20	2	11	15	8	59	3 x 120°	M5	13	M6	6
PNZ82	82	67	82	47	25	2.5	13	17	8	68	3 x 120°	M6	15	M6	8
PNZ95	95	70	95	55	30	2.5	14	18	8	82	3 x 120°	M6	15	M8	8
PNZ114	114	79	114	62	35	3	15	19	8	90	6 x 60°	M6	18	M8	6
PNZ124	124	82	124	75	45	3	15	19	8	110	6 x 60°	M6	21	M8	6
PNZ134	134	85	134	75	45	3	15	19	8	120	6 x 60°	M6	20	M8	8
PNZ152	152	93	152	95	60	3	17	21	8	130	6 x 60°	M6	20	M8	8
PNZ166	166	95	166	100	65	3	17	21	8	140	6 x 60°	M8	21	M8	8
PNZ195	195	108	195	115	75	3	19	23	8	170	6 x 60°	M8	23	M8	10
PNZ215	215	123	215	130	85	5	19	28	8	190	6 x 60°	M10	24	M8	12
PNZ240	240	139	240	150	100	7	21	29	8	220	6 x 60°	M10	28	M8	12